

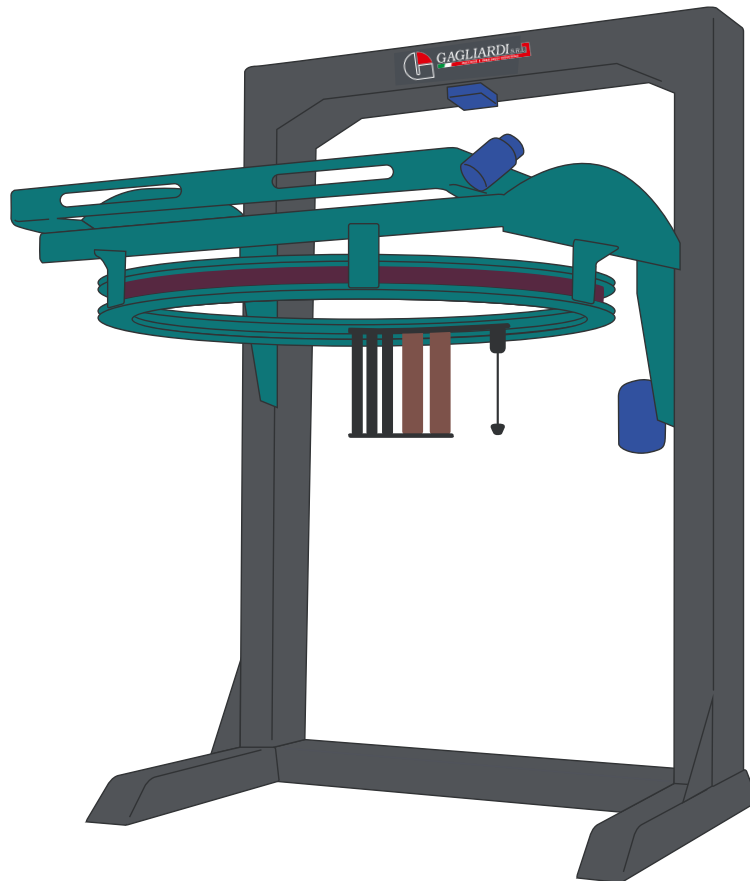

GAGLIARDI S.R.L.
MACCHINE E IMBALLAGGI INDUSTRIALI

WWW.GAGLIARDI-IMBALLAGGI.COM



OMEGA

AUTOMATIC WRAPPING MACHINE
EASY INSTALLATION

Rotary ring for wrapping pallets with stretch film

OMEGA
65 RPM



CONVEYOR HEIGHT

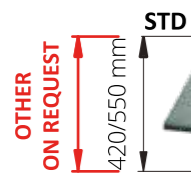

OMEGA DOUBLE
55 RPM



CONVEYOR HEIGHT

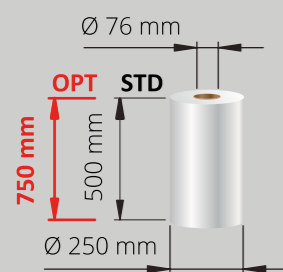
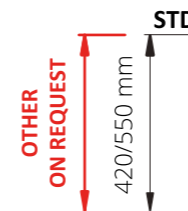

PALLET DIMENSIONS

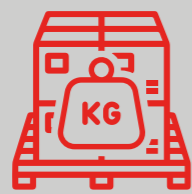

AT REQUEST

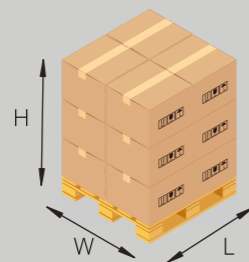

	Ø	WxL mm	
Max	1700	1200X1200	STD
Max	2050	1400X1400	BIG
Max	2500	1600X1600	SUPER BIG

APPLICATIONS





SELLING POINTS & MAIN OPTIONALS



ATLANTA PATENT

- IT** L'unica macchina a prestiro esterno, che non utilizza contatti elettrici sull'anello o altri sistemi complicati e costosi di generazione di corrente. È in grado di raggiungere una velocità di 140 pallet /h. Disponibile anche in versione 2 bobine.
- EN** Patented machine with an external pre-stretch drive system, which operates without electric sliding contacts/slip rings or other complex and expensive solutions such as electric generators. Capable of wrapping up to 140 pallet /h. Also available with double reels.
- FR** L'unique machine à motorisation externe du pré-étirage, qui n'utilise pas de contacts électriques sur l'anneau ou d'autres systèmes compliqués et coûteux de génération de courant. Possibilité d'atteindre une cadence de 140 pal. /h. Disponible également en version 2 bobines.
- DE** Die einzige Maschine Weltweit die das Vordehnsystem über eine aussen montierte Einheit steuert. Dadurch keine elektronischen Bauteile, Schleifringe sowie kein Generator auf dem Ring benötigt. Erreicht bis zu 140 Paletten/Stunde Auch als Doppelkopf Variante erhältlich.
- ES** La única maquina con pre-estiro externo, que no utiliza contactos eléctricos en el anillo o sistemas complicados y costosos de generación de corriente. Esta preparada para alcanzar una velocidad de 140 palets/h. Disponible también en versión de dos bobinas.



SAFETY SYSTEM

- IT** Sistema automatico anticaduta anello.
- EN** Automatic safety system secures the ring for access and maintenance.
- FR** Système automatique anti chute de l'anneaus.
- DE** Automatische Fallsicherung für den Ring.
- ES** Sistema automatico anticaida anillo.

SELF ADJUSTING WELDING UNIT

- IT** Sistema pinza taglio saldatura del film estensibile autoregolante per qualsiasi dimensione del pallet.
- EN** Film cutting, clamping and welding unit which is self-adjusting for any size of pallet.
- FR** Système de pince, coupe et soudure du film étirable à réglage automatique pour toutes dimensions de la palette.
- DE** Selbsteinstellendes Folienende Verschweißsystem passt sich auf sämtliche Palettengrößen automatisch an.
- ES** Sistema corte pinza soldadura del film extensible autorregulable para cualquier dimensión de palet.

CONTRAST PLATE

- IT** Saldatura su contrasto per garantire una perfetta saldatura della coda finale del film.
- EN** Welding is completed against a contrast plate, this guarantees a perfect film joint at the end of the final wrapping cycle.
- FR** Soudure sur contre-mors pour garantir une fixation parfaite du film en fin de cycle de banderolage.
- DE** Folienendeverschweißung gegen Kontrastplatte für eine perfekte Fixierung am Ende des Wickelzyklus.
- ES** Dispositivo de soldadura con placa de contraste, para garantizar el perfecto sellado de la cola del film.



SELLING POINTS & MAIN OPTIONALS

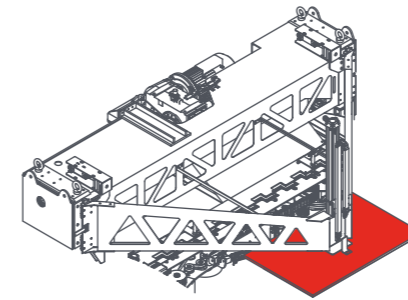

TOP PLATE UNIT

- IT** Pressore tenuta pallet.
- EN** Pallet top pressure unit.
- FR** Plateau stabilisateur de charge.
- DE** Palettenniederhalter.
- ES** Presor retención palet.

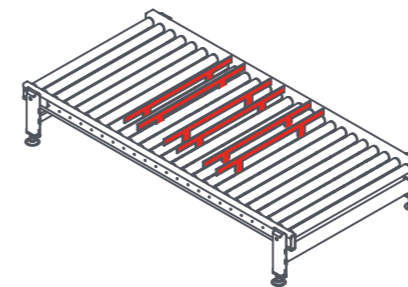

PALLET LIFTER

- IT** Sollevatore Pallet.
- EN** Pallet Lifter.
- FR** Releveur de charges.
- DE** Paletten Hubvorrichtung.
- ES** Elevador palet.

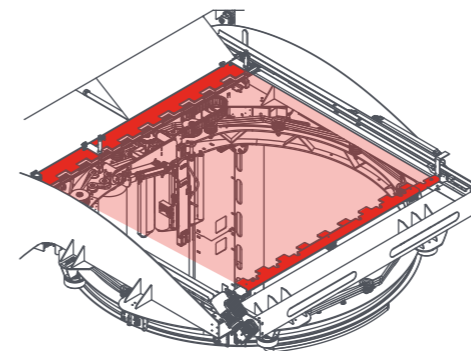

TOP COVER SYSTEM

- IT** Dispositivo di copertura ermetica o antipolvere del pallet.
- EN** Waterproof or Dustproof pallet cover device.
- FR** Dispositif de dépose de coiffe hermétique ou anti-poussière.
- DE** Deckblattaufleger für Staub-oder Wassergeschützte Palettenverpackung.
- ES** Dispositivo de cobertura hermetica o antipolvo del palet.

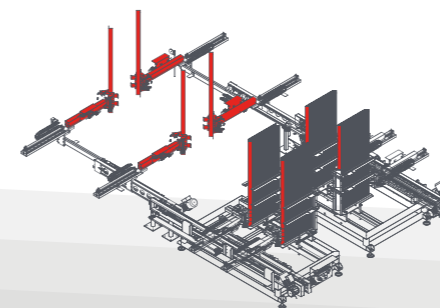

CORNER BOARDS APPLICATOR

- IT** Metti angolare automatico.
- EN** Automatic corner boards device to place automatically cardboard protectors to the load corners.
- FR** Dépose cornière automatique.
- DE** Automatische Kantenschutz-Applikator.
- ES** Colocador de cantoneras automático.



SELLING POINTS & MAIN OPTIONALS



ROPING SYSTEM

- IT** Sistema a corda: Permette di ridurre l'altezza del film formando un cordone che assicura una più efficiente stabilizzazione del carico.
- EN** Roping System: Reducing the film width, to form a rope ensuring a more effective load stabilisation.
- FR** Systeme permettant de réduire la laize du film en formant un cordon qui assure une meilleure stabilisation de la charge.
- DE** Schnurrvorrichtung: Reduzierung der Folienbreite zur Schnur um eine bessere Stabilisierung der Ladung zu gewährleisten.
- ES** Sistema de Cordón. Permite reducir la altura del film formando un cordón que asegura con mas eficacia la estabilidad de la carga.

JUMBO STRETCH FILM ROLL

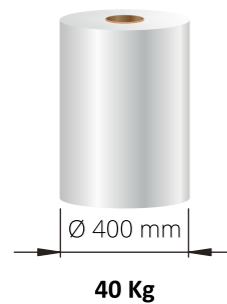

- IT** La bobina di polietilene può avere dimensioni Jumbo (40 Kg) e quindi una autonomia 3 volte superiore a quelle standard. Nella foto in alto, versione OMEGA PRS a 2 bobine.
- EN** Omega is available with a Jumbo sized reel (40 Kg). This solution increases the operating time between stops compared to the standard reel by almost 3 times.
- FR** La bobine peut être une jumbo 40 kg pour une autonomie 3 fois supérieure à une standard.
- DE** Die Folienrolle kann bis zu (40 Kg) betragen und dadurch eine 3 fache längere Laufzeit als bei Standardrollen.
- ES** La bobinade polietileno puede ser utilizada en Jumbo (40Kg) con una autonomía 3 veces superior a la estándar.



SPOOL FILM CARRIAGE

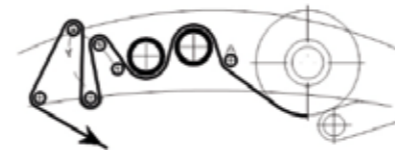

PATENTED

PRS POWER ROLLER STRETCH

- IT** Sistema di prestiro motorizzato a 3 rulli comandato elettronicamente con rapporti intercambiabili: 150 - 200 - 250%.
- EN** Motorised pre-stretch system with 3 driven rollers, electronically controlled with interchangeable ratios: 150 - 200 - 250%.
- FR** Système de pré-étirage motorisé et asservi à 3 rouleaux, rapports interchangeables: 150 - 200 - 250%.
- DE** Angetriebener Vordehnssystem mit 3 Vordehnrollen, elektronisch gesteuert mit leicht wechselbarer Zahnradsätzen: 150 - 200 - 250%.
- ES** Sistema de prestiro motorizado con 3 rodillos, comandado electrónicamente con desarrollos intercambiables: 150 - 200 - 250%.



CBA_AUTOMATIC FILM COIL CHANGE



WRAPPING PROGRAMS

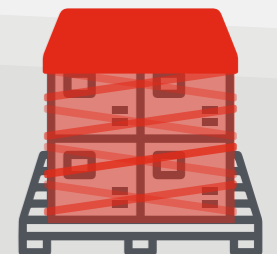
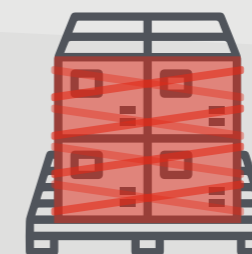

AUTOMATIC RANGE

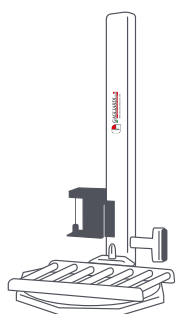

MYTHO STATION

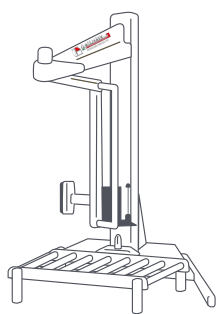

LYBRA STATION

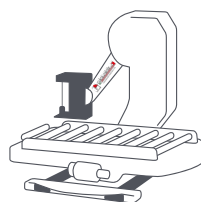

MYTHO A ARM

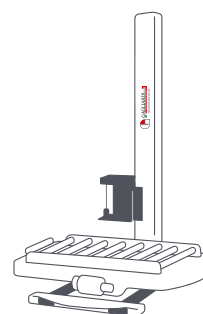

MYTHO A MAST

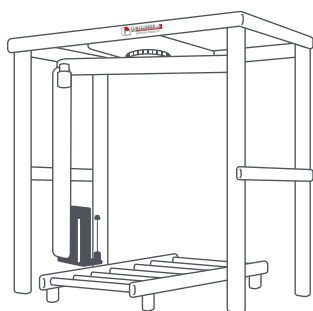

REVOLUTION LS

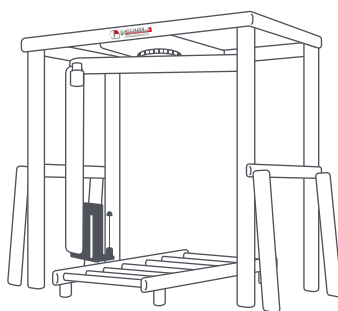

REVOLUTION HS

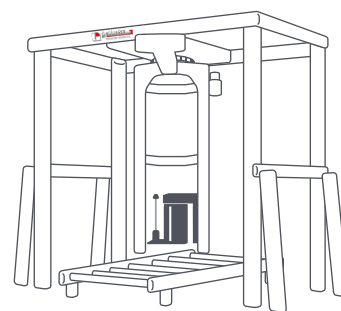

REVOLUTION HD

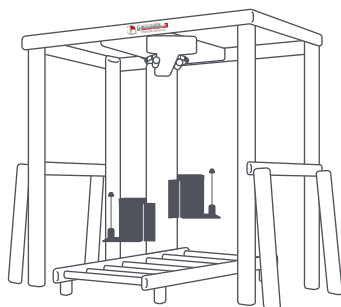

REVOLUTION DOUBLE

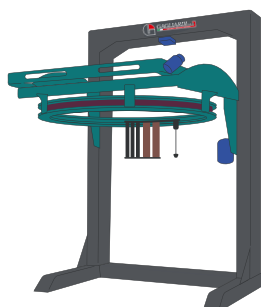

OMEGA

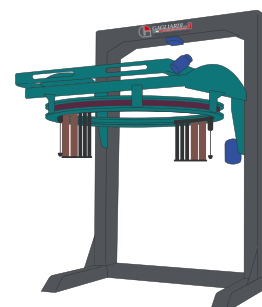

OMEGA DOUBLE



GAGLIARDI S.R.L.

MACCHINE E IMBALLAGGI INDUSTRIALI

WWW.GAGLIARDI-IMBALLAGGI.COM