

LYBRA



ATLANTA
S T R E T C H

LIBRA STATION

La macchina a braccio rotante robusta e affidabile per avvolgere pallet con film estensibile. Ingombro ridotto ed elevate prestazioni.

Compact, high performance rotating arm machine for wrapping pallets with stretch film. Reliable, robust construction.

La machine à bras tournant robuste et fiable pour banderoller des charges palettisées sous film étirable avec un encombrement réduit et de grandes prestations.

Die robuste und zuverlässige Vollautomatische Dreharm Stretchwickel Maschine mit geringem Platzbedarf und hohe Leistung.

Máquina de brazo rotante robusta y fiable para la envoltura de palet con film extensible de espacio reducido y alta prestaciones.

Надежный паллетоупаковщик с вращающейся рукой для упаковки паллет в стрейч пленку



Distributore elettrico.

Electrical distributor.

Distributeur électrique.

Elektrischer Verteiler.

Distribuidor eléctrico.

Электрический распределитель.

Ralla per rotazione braccio ad alta affidabilità.

Gears for rotation of the arm with high reliability.

Mécanisme pour rotation du bras à haute fiabilité.

Getriebeantrieb mit hoher Zuverlässigkeit.

Engranages para rotación del brazo de gran fiabilidad.

Гнездо высокой надежности для вращения стрелы.



LYBRA AUTO



- ▶ Avvolgitore automatico stand alone con sistema di taglio e aggancio, semplice e affidabile.
- ▶ Die robuste und zuverlässige Vollautomatische Dreharm Stretchwickel Maschine mit geringem Platzbedarf und hohe Leistung.
- ▶ Automatic stand alone wrapping arm with clamp and cutting system, simple and reliable.
- ▶ Envolvedora de mesa giratoria automática fuera de línea con grupo pinza y corte film, simple y fiable.
- ▶ Banderoleuse automatique à bras hors ligne avec groupe pince et coupe, simple et fiable.
- ▶ автоматической паллетоупаковщик с системой отрезания и крепления пленки.

- ▶ Facile da usare, 99 cicli di avvolgimento preimpostati e possibilità di programmare un numero illimitato di opzioni.
- ▶ Easy to use, 99 pre-set wrapping cycles and the possibility of programming an unlimited number of options.
- ▶ Utilisation facile, 99 programmes mémorisables comprenant un nombre important de cycles et fonctions pour résoudre les cas les plus difficiles.
- ▶ Einfach zum Bedienen, 99 Vorprogrammierte Wickelprogramme mit unbegrenzten einstellbaren Parameter von Bedienungstafel.
- ▶ Fácil de usar, 99 ciclos de envoltura predispuesta y posibilidad de programar un número ilimitado de opciones.
- ▶ Простая в использовании, 99 циклов обмотки и возможность программировать неограниченное кол-во опций.





🇬🇧 Technical Characteristics	Lybra Auto / Lybra / Lybra W
Total installed power	min 1.2 (kW) max 2.2 (kW)
Standard input voltage	230V three-phase - 50 Hz - 6A
Electrical system and motors protection	IP 54
Max pallet dimensions	1000 x 1200 mm
Standard pallet height	2500 mm
Maximum arm rotation speed	12 rpm

- ▶ Sistema di prestiro elettronico con inserimento rapido del film estensibile. (IRF SYSTEM).
- ▶ Elektronisch gesteuerte Vordehnung mit Folienschnellwechselsystem (I.R.F. SYSTEM).
- ▶ Electronically controlled pre-stretch carriage with rapid film loading system. (IRF SYSTEM).
- ▶ Sistema de pre-estiro electrónico con inserción rápida del film extensible. (I.R.F. SYSTEM).
- ▶ Pré-étirage motorisé et asservi à chargement rapide du film étirable (IRF SYSTEM).
- ▶ Электронная система престрейча с быстрой заменой бобины (IRF System).









LYBRA

-  Versione semiautomatica.
-  Semi-automatic version.
-  Version semi-automatique.
-  Semi-automatische Version.
-  Versión Semi-automática
-  Полуавтоматическая версия.







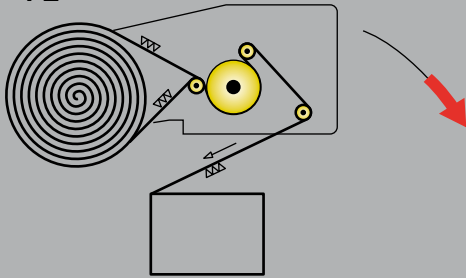

LYBRA W

-  Versione a muro.
-  Wall mounted system.
-  Version murale.
-  Wand-Version.
-  Versión de pared.
-  Крепление к стене.









FE

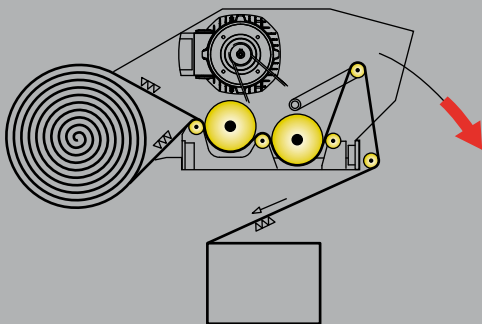

-  Frizione elettromagnetica regolabile da pannello comandi.
-  Electromagnetic friction adjustable from control panel.
-  Frein électromagnétique réglable depuis le panneau de commande.
-  Elektromagnetische Bremse auf Umlenkwalze vom Bedienpult einstellbar.
-  Fricción electromagnética regulable desde el panel de comandos.
-  Электромагнитный тормоз: регулируется с панели управления.







PRS POWER ROLLER STRETCH

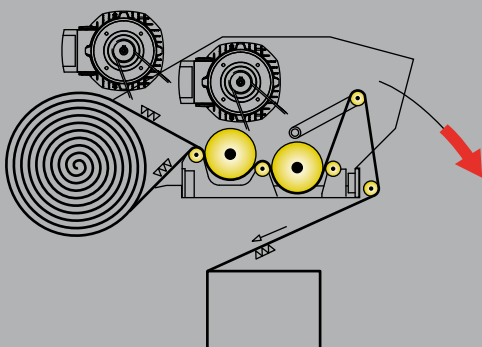

-  Sistema di prestiro motorizzato comandato elettronicamente con rapporti intercambiabili: 150 - 200 - 250%.
-  Motorized pre-stretch system electronically controlled with interchangeable ratios: 150 - 200 - 250%.
-  Système de pré-étirage motorisé et asservi à rapports interchangeables: 150 - 200 - 250%.
-  Angetriebener Vordehnssystem elektronisch gesteuert mit leicht wechselbarer Zahnradsätzen: 150 - 200 - 250%.
-  Sistema de prestiro motorizado comandado electronicamente con desarrollos intercambiables: 150 - 200 - 250%.
-  Система престрейча с 3-мя моторизованными роликами: 150-200-250%.

PS POWER STRETCH



-  Sistema di prestiro motorizzato a 3 rulli con 2 motori e variazione continua da 120 a 350% regolabile da quadro comandi.
-  Motorized pre-stretch system with 3 driven rollers and 2 motors adjustable between 120 to 350% from control panel.
-  Système de pré-étirage motorisé et asservi à 3 rouleaux et 2 moteurs, rapport ajustable de 120 à 350% depuis le panneau de commande.
-  Angetriebener Vordehnssystem mit 3 Vordehnrollen und 2 Motoren, stufenlos regelbare Werte zwischen 120 und 350% von Bedienpult.
-  Sistema de prestiro motorizado con 3 rodillos y 2 motores, regulable da 120 a 350% desde el panel de comandos.
-  система престрейча с 3-мя моторизованными роликами и 2-мя моторами: 120-350%.

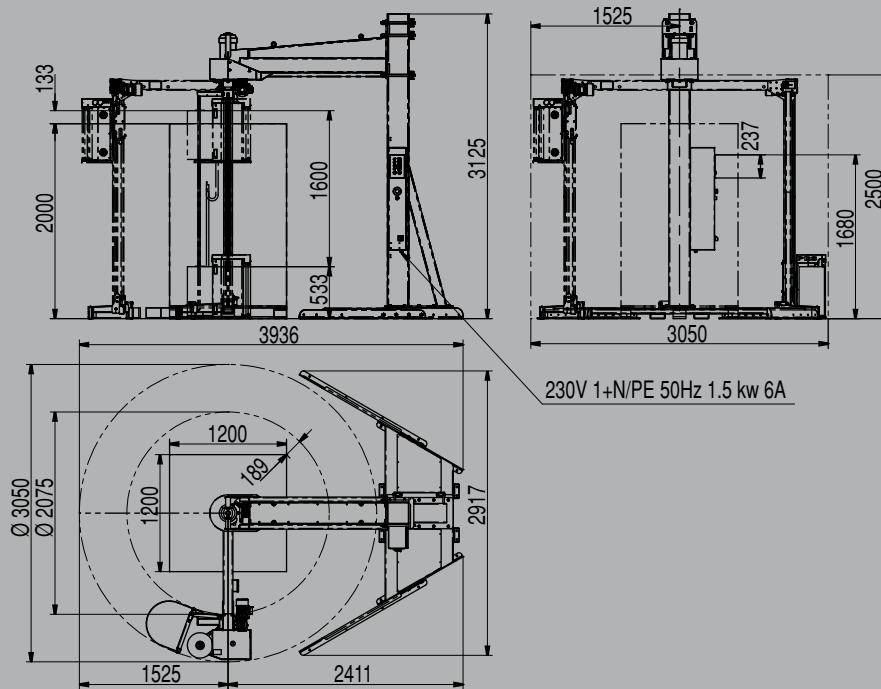

OPTIONS

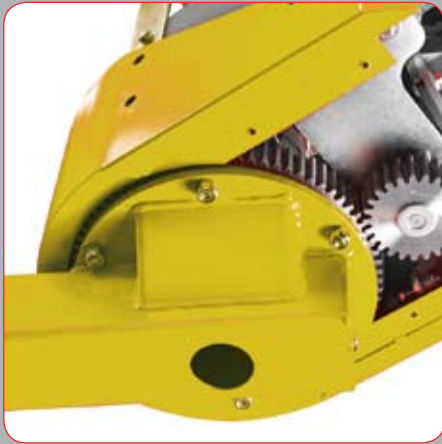

- Pressore tenuta pallet.
- Pallet top pressure unit.
- Plateau stabilisateur de charge.
- Palettenniederhalter.
- Prensor retención palet.
- Прижим для паллеты.



- Sistema saldatura del film estensibile autoregolante per qualsiasi dimensione del pallet.
- Film weld unit self adjusting for any size of pallet.
- Système de soudure du film étirable à réglage automatique pour toutes dimensions de la palette.
- Selbsteinstellendes Folienende Verschweißsystem passt sich auf sämtliche Palettengrößen automatisch an.
- Sistema soldadura del film extensible autorregulable para cualquier dimensión de palet.
- Система автоматического отрезания и припайки пленки.



- Sistema a corda: Permette di ridurre l'altezza del film formando un cordone che assicura una più efficiente stabilizzazione del carico.
- Roping System: Reducing the film width to form a rope to ensure more effective load stabilisation.
- Systeme permettant de réduire la laize du film en formant un cordon qui assure une meilleure stabilisation de la charge.
- Schnurrvorrichtung: Reduzierung der Folienbreite zur Schnur um eine bessere Stabilisierung der Ladung zu gewährleisten.
- Sistema Cordón. Permite reducir la altura del film formando un cordón que asegura con mas eficacia la estabilidad de la carga.
- Система автоматического отрезания и припайки пленки.

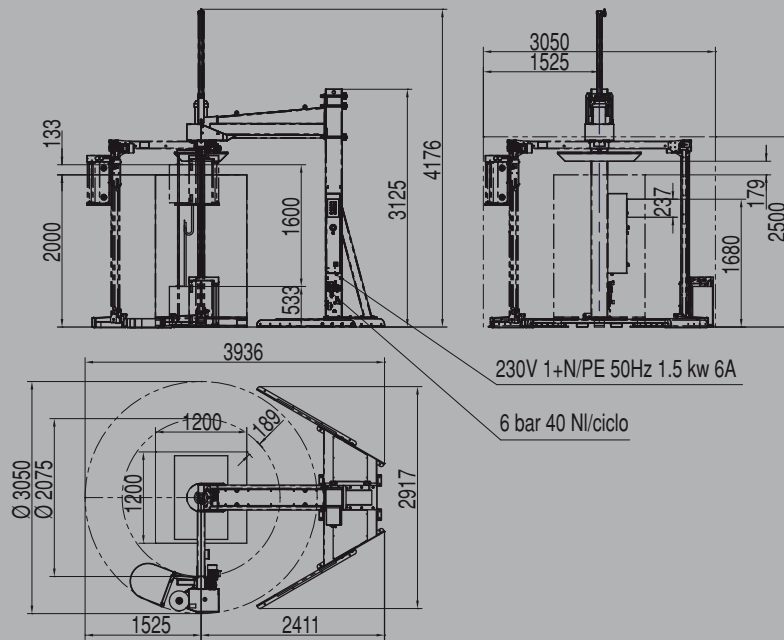

Dati Tecnici

Lybra Station

Potenza totale istallata	2.5 (kW)
Tensione alimentazione standard	400V trifase - 50 Hz - 6A
Protezione impianto elettrico e motori	IP 54
Dimensione max pallet	1000 x 1200 mm
Altezza std pallet	2400 mm
Portata max	1500 Kg
Velocità massima rotazione	12 rpm

Technische Daten

Lybra Station

Gesamte Leistung	2.5 (kW)
Anschluss-Spannung	400V three-phase - 50 Hz - 6A
Elektroanlage und Motore Schutzart	IP 54
Max. Palettenabmessung	1000 x 1200 mm
Max. Standard Wickelhöhe	2400 mm
Max. Ladungsgewicht	1500 Kg
Max. Drehgeschwindigkeit	12 rpm

Technical Characteristics

Lybra Station

Total installed power	2.5 (kW)
Standard input voltage	400V three-phase - 50 Hz - 6A
Electrical system and motors protection	IP 54
Max pallet dimensions	1000 x 1200 mm
Standard pallet height	2400 mm
Max capacity	1500 Kg
Maximum rotation speed	12 rpm

Datos Técnicos

Lybra Station

Potencia total instalada	2.5 (kW)
Tensión de alimentación estandar	400V trifase - 50 Hz - 6A
Protección montaje eléctrico y motores	IP 54
Dimensión máx. palet	1000 x 1200 mm
Altura estandar palet	2400 mm
Peso máx.	1500 Kg
Velocidad máxima rotación	12 rpm

Données Techniques

Lybra Station

Puissance totale installée	2.5 (kW)
Tension alimentation standard	400V three-phase - 50 Hz - 6A
Protection installation électrique et moteurs	IP 54
Dimensions maximum palette	1000 x 1200 mm
Hauteur standard palette	2400 mm
Portée maximum	1500 Kg
Vitesse de rotation maxi	12 rpm

Технические данные

Lybra Station

Установленная мощность	2.5 (kW)
Стандартное напряжение	400V three-phase - 50 Hz - 6A
Уровень защиты	IP 54
Макс. Размеры паллет	1000 x 1200 mm
Стандартная высота паллет	2400 mm
Макс. грузоподъемность	1500 Kg
Макс. скорость вращения стола	12 rpm

Le indicazioni riportate non sono impegnative.
 The information given is not binding.
 Les indications fournies ne sont pas contraignantes.
 Die Angaben sind unverbindlich.
 Las indicaciones presentadas no nos comprometen.
 Предоставленная информация не является обязательной.



ATLANTA STRETCH S.p.A
 Via Chiesa di Camerano, 30
 47824 Poggio Berni
 (Rimini) Italia
 Tel. +39 0541 627145
 Fax +39 0541 627220
 www.atlantastretch.com
 sales@atlantastretch.com



Atlanta Deutschland GmbH
 Atlanta Stretch Sweden AB
 Atlanta Packaging SA - Spain
 Atlanta Packaging Ltd - UK
 Atlanta France Sarl
 Atlanta Packaging Systems Australasia
 Atlanta Stretch Russia